



# DTH Drilling Equipment

## KEMAICO USA CORPORATION



**GLOBAL DRILLING INDUSTRY EXPERTS**



## High Air Pressure DTH Hammer -With Foot Valve Code

### DTH Hammer With Foot Valve ( i.e. MQL5 )

M	QL	5
Our Company: Maxdrill	Bit shank: D- DHD Bit Shank QL5- QL50 Bit Shank SD5-SD5 Bit Shank	Inch: 5" hammer

Decomposition	Item	Part Number	Description
---------------	------	-------------	-------------

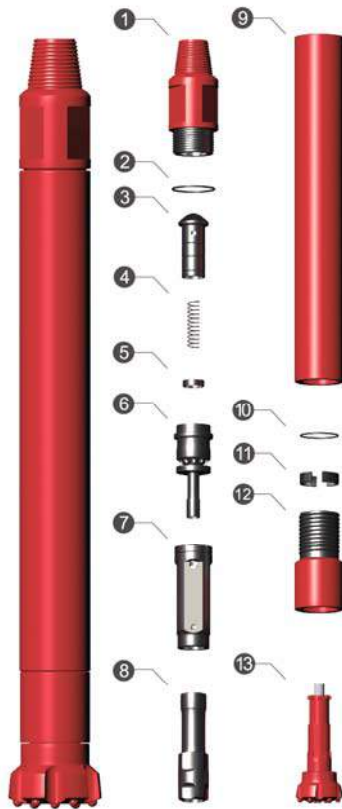

1	MD5501	Top Sub
2	MD5502	"O" Ring of Top Sub
3	MD5503	Check Valve
4	MD5504	Spring
5	MD5505	Compression Buffer
6	MD5506	Air Distributor
7	MD5507	Internal Cylinder
8	MD5508	Piston
9	MD5509	External Cylinder
10	MD5510	"O" Ring of Stop Ring
11	MD5511	Stop Ring
12	MD5512	Drive Chuck
13	MD5513	Drill Bit

### Technical Parameters

Length(Less bit)	1214mm
Weight(Less bit)	79.00Kg
External Diameter	Ø125mm
Bit Shank	Cop54 / DHD350R
Hole Range	ø135-ø155
Connection Thread	API 2 3/8" Reg API 3 1/2" Reg
Working Pressure	1.0-2.5Mpa
Impact Rate at 1.7Mpa	23HZ
Recommended Rotation Speed	20-30r/min
Air Consumption	145-350PSI 600-836CFM

Product Number

# MD55

Decomposition	Item	Part Number	Description
	1	MSD501	Top Sub
	2	MSD502	"O" Ring of Top Sub
	3	MSD503	Check Valve
	4	MSD504	Spring
	5	MSD505	Compression Buffer
	6	MSD506	Air Distributor
	7	MSD507	Internal Cylinder
	8	MSD508	Piston
	9	MSD509	External Cylinder
	10	MSD510	"O" Ring of Stop Ring
	11	MSD511	Stop Ring
	12	MSD512	Drive Chuck
	13	MSD513	Drill Bit

Product Number

# MSD5

## Technical Parameters

Length(Less bit)	1175mm
Weight(Less bit)	72.50Kg
External Diameter	Ø125mm
Bit Shank	SD5
Hole Range	ø135- ø 155
Connection Thread	API 3 1/2" Reg
Working Pressure	1.0-2.5Mpa
Impact Rate at 1.7Mpa	23HZ
Recommended Rotation Speed	20-30r/min
Air Consumption	145-350PSI 600-836CFM

Decomposition	Item	Part Number	Description
---------------	------	-------------	-------------

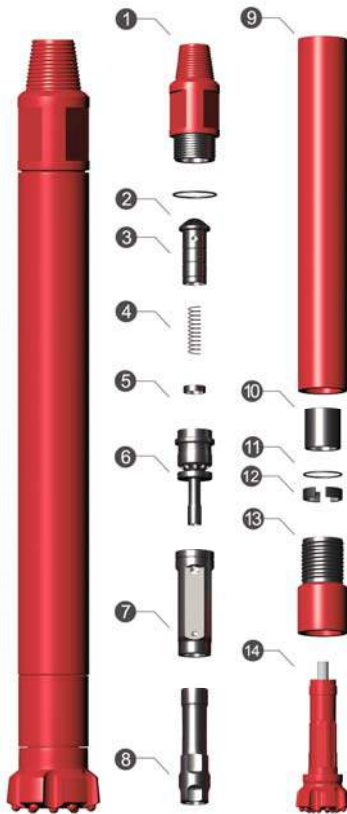

1	MQL501	Top Sub
2	MQL502	"O" Ring of Top Sub
3	MQL503	Check Valve
4	MQL504	Spring
5	MQL505	Compression Buffer
6	MQL506	Air Distributor
7	MQL507	Internal Cylinder
8	MQL508	Piston
9	MQL509	External Cylinder
10	MQL510	Guided Sleeve
11	MQL511	"O" Ring of Stop Ring
12	MQL512	Stop Ring
13	MQL513	Drive Chuck
14	MQL514	Drill Bit

### Technical Parameters

Length(Less bit)	1156mm
Weight(Less bit)	73.00Kg
External Diameter	Ø125mm
Bit Shank	QL50
Hole Range	ø135- ø 155
Connection Thread	API 3 1/2" Reg
Working Pressure	1.0-2.5Mpa
Impact Rate at 1.7Mpa	23HZ
Recommended Rotation Speed	20-30r/min
Air Consumption	145-350PSI 600-836CFM

Product Number

# MQL5



## High Air Pressure -Without Foot Valve DTH Hammer Code

### DTH Hammer Without Foot Valve ( i.e. MQL4A )

M	QL	4	A/S
Our Company: Maxdrill	Bit shank: D- DHD Bit Shank QL4- QL40 Bit Shank SD4-SD4 Bit Shank BR1-BR1 Bit Shank M-Mission Bit Shank N-NUMA Bit Shank	Inch: 4" hammer	A-Bit without foot valve S-Smaller size than general DTH Hammer

Decomposition	Item	Part Number	Description
	1	MD55A01	Top Sub
	2	MD55A02	"O" Ring of Top Sub
	3	MD55A03	Check Valve
	4	MD55A04	Spring
	5	MD55A05	Air Distributor
	6	MD55A06	Internal Cylinder
	7	MD55A07	Piston
	8	MD55A08	External Cylinder
	9	MD55A09	Guided Sleeve
	10	MD55A10	"O" Ring of Stop Ring
	11	MD55A11	Stop Ring
	12	MD55A12	Drive Chuck
	13	MD55A13	Drill Bit

**Product Number**

**MD55A**

**Technical Parameters**

Length(Less bit)	1110mm
Weight(Less bit)	69.00Kg
External Diameter	Ø125mm
Bit Shank	Cop54 / DHD350R
Hole Range	ø 135- ø 155
Connection Thread	API 2 3/8" Reg API 3 1/2" Reg
Working Pressure	1.0-2.5Mpa
Impact Rate at 1.7Mpa	23HZ
Recommended Rotation Speed	20-30r/min
Air Consumption	145-350PSI 600-836CFM

Decomposition	Item	Part Number	Description
---------------	------	-------------	-------------

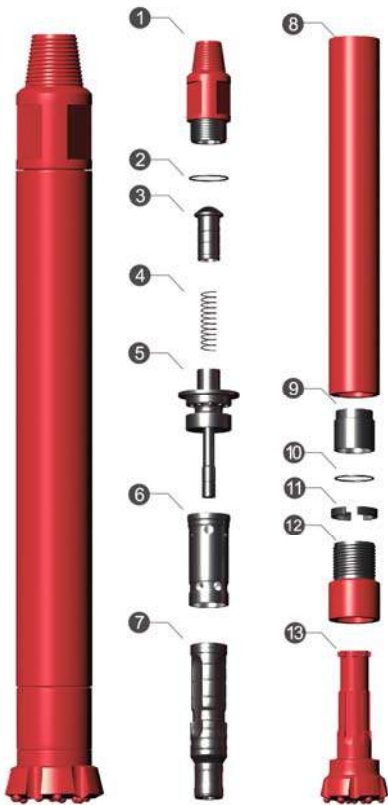

1	MD55S01	Top Sub
2	MD55S02	"O" Ring of Top Sub
3	MD55S03	Check Valve
4	MD55S04	Spring
5	MD55S05	Air Distributor
6	MD55S06	Internal Cylinder
7	MD55S07	Piston
8	MD55S08	External Cylinder
9	MD55S09	Guided Sleeve
10	MD55S10	"O" Ring of Stop Ring
11	MD55S11	Stop Ring
12	MD55S12	Drive Chuck
13	MD55S13	Drill Bit

Product Number

**MD55S**

### Technical Parameters

Length(Less bit)	1110mm
Weight(Less bit)	56.00Kg
External Diameter	Ø116mm
Bit Shank	Cop54 / DHD350R
Hole Range	ø 127- ø 145
Connection Thread	API 2 3/8" Reg API 3 1/2" Reg
Working Pressure	1.0-2.5Mpa
Impact Rate at 1.7Mpa	23HZ
Recommended Rotation Speed	20-30r/min
Air Consumption	145-350PSI 600-836CFM



Decomposition	Item	Part Number	Description
---------------	------	-------------	-------------

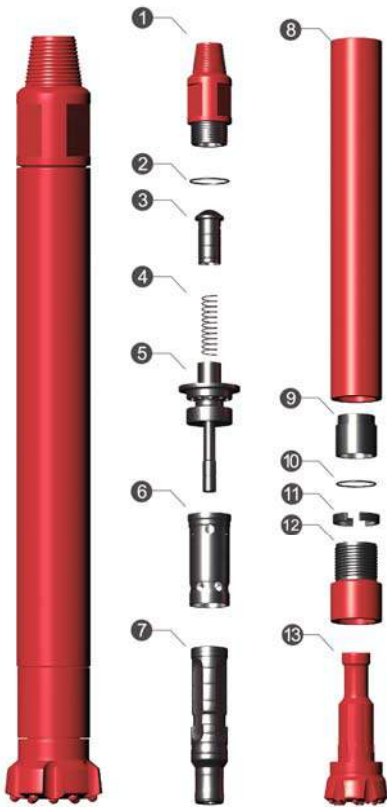

1	MM5A01	Top Sub
2	MM5A02	"O" Ring of Top Sub
3	MM5A03	Check Valve
4	MM5A04	Spring
5	MM5A05	Air Distributor
6	MM5A06	Internal Cylinder
7	MM5A07	Piston
8	MM5A08	External Cylinder
9	MM5A09	Guided Sleeve
10	MM5A10	"O" Ring of Stop Ring
11	MM5A11	Stop Ring
12	MM5A12	Drive Chuck
13	MM5A13	Drill Bit

## Product Number

# MM5A

## Technical Parameters

Length(Less bit)	1110mm
Weight(Less bit)	73.00Kg
External Diameter	Ø125mm
Bit Shank	Mission50A
Hole Range	ø 135- ø 155
Connection Thread	API 2 3/8" Reg API 3 1/2" Reg
Working Pressure	1.0-2.5Mpa
Impact Rate at 1.7Mpa	23HZ
Recommended Rotation Speed	20-30r/min
Air Consumption	145-350PSI 600-836CFM

Decomposition	Item	Part Number	Description
	1	MSD5A01	Top Sub
	2	MSD5A02	"O" Ring of Top Sub
	3	MSD5A03	Check Valve
	4	MSD5A04	Spring
	5	MSD5A05	Air Distributor
	6	MSD5A06	Internal Cylinder
	7	MSD5A07	Piston
	8	MSD5A08	External Cylinder
	9	MSD5A09	Guided Sleeve
	10	MSD5A10	"O" Ring of Stop Ring
	11	MSD5A11	Stop Ring
	12	MSD5A12	Drive Chuck
	13	MSD5A13	Drill Bit

Product Number

# MSD5A

## Technical Parameters

Length(Less bit)	1090mm
Weight(Less bit)	70.00Kg
External Diameter	Ø125mm
Bit Shank	SD5
Hole Range	ø 135- ø 155
Connection Thread	API 2 3/8" Reg API 3 1/2" Reg
Working Pressure	1.0-2.5Mpa
Impact Rate at 1.7Mpa	23HZ
Recommended Rotation Speed	20-30r/min
Air Consumption	145-350PSI 600-836CFM

Decomposition	Item	Part Number	Description
	1	MQL5A01	Top Sub
	2	MQL5A02	"O" Ring of Top Sub
	3	MQL5A03	Check Valve
	4	MQL5A04	Spring
	5	MQL5A05	Air Distributor
	6	MQL5A06	Internal Cylinder
	7	MQL5A07	Piston
	8	MQL5A08	External Cylinder
	9	MQL5A09	Guided Sleeve
	10	MQL5A10	"O" Ring of Stop Ring
	11	MQL5A11	Stop Ring
	12	MQL5A12	Drive Chuck
	13	MQL5A13	Drill Bit

Product Number

**MQL5A**

### Technical Parameters

Length(Less bit)	1090mm
Weight(Less bit)	67.00Kg
External Diameter	Ø125mm
Bit Shank	QL50
Hole Range	ø 135- ø 155
Connection Thread	API 2 3/8" Reg API 3 1/2" Reg
Working Pressure	1.0-2.5Mpa
Impact Rate at 1.7Mpa	23HZ
Recommended Rotation Speed	20-30r/min
Air Consumption	145-350PSI 600-836CFM

# Bit Face Shape Selection

## Concave Face

The all-round application bit face specifically for medium hard and homogenous rock formations. Good hole deviation control and good flushing capacity.



## Convex Face

For high penetration rates in soft to medium-hard with low to medium air pressures. It is the most resistance to steel wash, and may reduce the load and wear on the gauge buttons, but poor hole deviation control.

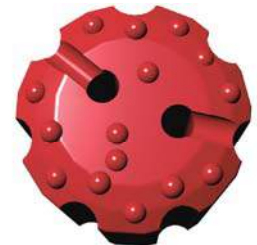

## Flat Face

This kind of face shape is suitable for hard to very hard and abrasive rock formations in applications with high air pressures. Good penetration rates and resistance to steel wash.



## DTH Bit Code ( i.e. 150MQL50CC )

150	M	QL50	CC/CV/FF
Bit Diameter: 150mm	Our company: Maxdrill	Bit Shank: QL50-QL50 Bit Shank SD5-SD5 Bit Shank M50-Misson50 Bit Shank D-DHD Bit Shank N-NUMA Bit Shank	Front Design: CC-Concave CV-Convex FF-Flat Face

# Carbide Button Shape Selection



## Domed/ Round Button

Domed / Round buttons are usually used as gauge buttons of DTH Bits, suitable for very abrasive and very hard formations.



## Parabolic/Semi-Ballistic Button

Parabolic buttons are usually used as gauge buttons and front buttons of DTH Bits, suitable for medium abrasive and hard formations.



## Ballistic Button

Ballistic buttons are usually used as front buttons of DTH Bits, suitable for medium abrasive and medium hard formations. They can also be used as gauge buttons if the rock is soft.



## Sharp Button

Sharp buttons are usually used as front buttons of DTH Bits for soft formations where fast penetration rates are possible and button breakage is minimal.

**MD55  
DHD350R  
COP54**

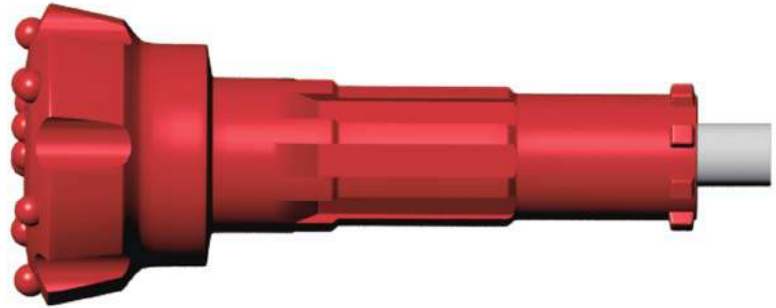

Face	Diameter		Part No.	No. x Button (mm)			Flushing holes	Weight
	Dia.	Inch		Outer	Inner	Front		kg
Flat	140	5 1/2	140MD55FF	7 x φ18		7 x φ14	2	17
	146	5 3/4	146MD55FF	7 x φ18		7 x φ14	2	18
	150	5 7/8	150MD55FF	8 x φ18		8 x φ14	2	19
	152	6	152MD55FF	8 x φ18		8 x φ14	2	20

Face	Diameter		Part No.	No. x Button (mm)			Flushing holes	Weight
	Dia.	Inch		Outer	Inner	Front		kg
Concave	140	5 1/2	140MD55CC	7 x φ18	4 x φ14	3 x φ14	2	17
	146	5 3/4	146MD55CC	7 x φ18	4 x φ14	3 x φ14	2	18
	150	5 7/8	150MD55CC	8 x φ18	4 x φ14	4 x φ14	2	19
	152	6	152MD55CC	8 x φ18	4 x φ14	4 x φ14	2	20

Face	Diameter		Part No.	No. x Button (mm)			Flushing holes	Weight
	Dia.	Inch		Outer	Inner	Front		kg
Convex	140	5 1/2	140MD55CV	7 x φ18	4 x φ14	3 x φ14	2	17
	146	5 3/4	146MD55CV	7 x φ18	4 x φ14	3 x φ14	2	18
	150	5 7/8	150MD55CV	8 x φ18	4 x φ14	4 x φ14	2	19
	152	6	152MD55CV	8 x φ18	4 x φ14	4 x φ14	2	20

# M50A

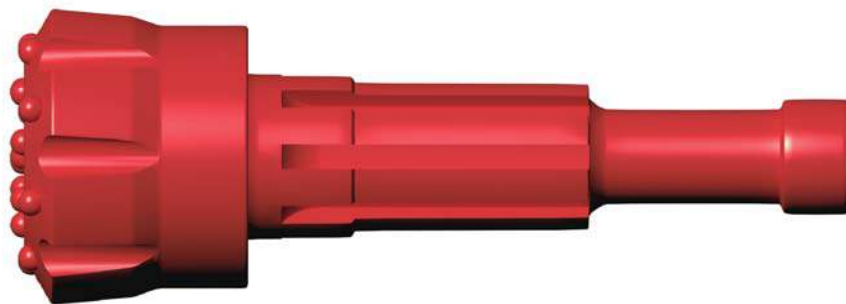

Face	Diameter		Part No.	No. x Button (mm)			Flushing holes	Weight
	Dia.	Inch		Outer	Inner	Front		kg
Flat	140	5 1/2	140MM50FF	7 x φ18		7 x φ14	2	15.7
	146	5 3/4	146MM50FF	7 x φ18		7 x φ14	2	16.7
	150	5 7/8	150MM50FF	8 x φ18		8 x φ14	2	17.7
	152	6	152MM50FF	8 x φ18		8 x φ14	2	18.7

Face	Diameter		Part No.	No. x Button (mm)			Flushing holes	Weight
	Dia.	Inch		Outer	Inner	Front		kg
Concave	140	5 1/2	140MM50CC	7 x φ18	4 x φ14	3 x φ14	2	15.7
	146	5 3/4	146MM50CC	7 x φ18	4 x φ14	3 x φ14	2	16.7
	150	5 7/8	150MM50CC	8 x φ18	4 x φ14	4 x φ14	2	17.7
	152	6	152MM50CC	8 x φ18	4 x φ14	4 x φ14	2	18.7

Face	Diameter		Part No.	No. x Button (mm)			Flushing holes	Weight
	Dia.	Inch		Outer	Inner	Front		kg
Convex	140	5 1/2	140MM50CV	7 x φ18	4 x φ14	3 x φ14	2	15.7
	146	5 3/4	146MM50CV	7 x φ18	4 x φ14	3 x φ14	2	16.7
	150	5 7/8	150MM50CV	8 x φ18	4 x φ14	4 x φ14	2	17.7
	152	6	152MM50CV	8 x φ18	4 x φ14	4 x φ14	2	18.7

# SD5



Face	Diameter		Part No.	No. x Button (mm)			Flushing holes	Weight
	Dia.	Inch		Outer	Inner	Front		kg
Flat	140	5 1/2	140MSD5FF	7 x φ18		7 x φ14	2	16.5
	146	5 3/4	146MSD5FF	7 x φ18		7 x φ14	2	17.5
	150	5 7/8	150MSD5FF	8 x φ18		8 x φ14	2	18.5
	152	6	152MSD5FF	8 x φ18		8 x φ14	2	19.5

Face	Diameter		Part No.	No. x Button (mm)			Flushing holes	Weight
	Dia.	Inch		Outer	Inner	Front		kg
Concave	140	5 1/2	140MSD5CC	7 x φ18	4 x φ14	3 x φ14	2	16.5
	146	5 3/4	146MSD5CC	7 x φ18	4 x φ14	3 x φ14	2	17.5
	150	5 7/8	150MSD5CC	8 x φ18	4 x φ14	4 x φ14	2	18.5
	152	6	152MSD5CC	8 x φ18	4 x φ14	4 x φ14	2	19.5

Face	Diameter		Part No.	No. x Button (mm)			Flushing holes	Weight
	Dia.	Inch		Outer	Inner	Front		kg
Convex	140	5 1/2	140MSD5CV	7 x φ18	4 x φ14	3 x φ14	2	16.5
	146	5 3/4	146MSD5CV	7 x φ18	4 x φ14	3 x φ14	2	17.5
	150	5 7/8	150MSD5CV	8 x φ18	4 x φ14	4 x φ14	2	18.5
	152	6	152MSD5CV	8 x φ18	4 x φ14	4 x φ14	2	19.5



# QL50



Face	Diameter		Part No.	No. x Button (mm)			Flushing holes	Weight
	Dia.	Inch		Outer	Inner	Front		kg
Flat	140	5 1/2	140MQL50FF	7 x φ18		7 x φ14	2	16.5
	146	5 3/4	146MQL50FF	7 x φ18		7 x φ14	2	17.5
	150	5 7/8	150MQL50FF	8 x φ18		8 x φ14	2	18.5
	152	6	152MQL50FF	8 x φ18		8 x φ14	2	19.5

Face	Diameter		Part No.	No. x Button (mm)			Flushing holes	Weight
	Dia.	Inch		Outer	Inner	Front		kg
Concave	140	5 1/2	140MQL50CC	7 x φ18	4 x φ14	3 x φ14	2	16.5
	146	5 3/4	146MQL50CC	7 x φ18	4 x φ14	3 x φ14	2	17.5
	150	5 7/8	150MQL50CC	8 x φ18	4 x φ14	4 x φ14	2	18.5
	152	6	152MQL50CC	8 x φ18	4 x φ14	4 x φ14	2	19.5

Face	Diameter		Part No.	No. x Button (mm)			Flushing holes	Weight
	Dia.	Inch		Outer	Inner	Front		kg
Convex	140	5 1/2	140MQL50CV	7 x φ18	4 x φ14	3 x φ14	2	16.5
	146	5 3/4	146MQL50CV	7 x φ18	4 x φ14	3 x φ14	2	17.5
	150	5 7/8	150MQL50CV	8 x φ18	4 x φ14	4 x φ14	2	18.5
	152	6	152MQL50CV	8 x φ18	4 x φ14	4 x φ14	2	19.5



## **KEMAICO USA CORPORATION**

 Address: 300 Knightsbridge Pkwy Ste.113 , Lincolnshire , IL 60069

 Tel: 1-847-9136878 Fax:1-847-9136879

 Email: [office@kemaico.com](mailto:office@kemaico.com) [info@kemaico.com](mailto:info@kemaico.com)

 Web: [www.kemaico.com](http://www.kemaico.com)

